

Technical Bulletin

Bulletin Number: 462 Revision Number: R-02

Release Date: March 22, 1993 Revision Date: July 31, 1998

SUBJECT: MPC DISPLAY WINDOW PROTECTIVE COVER KIT

MODELS AFFECTED: All MPC venders, except Coke Landscape.

SERIAL BREAK: MPC Venders serialized 0001-3203DO to 0001-6111AR.

REASON: To provide a kit to protect the display window from vandalism.

ORDER: 531,010,10x.x4 MPC Display Window Cover Kit

Kit Contents:

- | | |
|--------------------|--------------------------------|
| 1 - 801,807,16x.x1 | MPC Display Cover Protector |
| 1 - 531,010,01x.x3 | Template - MPC Display Cover |
| 2 - 900,700,94x.x1 | Nylon Washer |
| 2 - 905,300,34x.x1 | Standoff - Metal MPC Display |
| 4 - 900,201,45x.x1 | Carriage Bolt, 1/4" - 20 x 1/2 |
| 4 - 900,800,67x.x1 | Keps Nut, 1/4 - 20 |

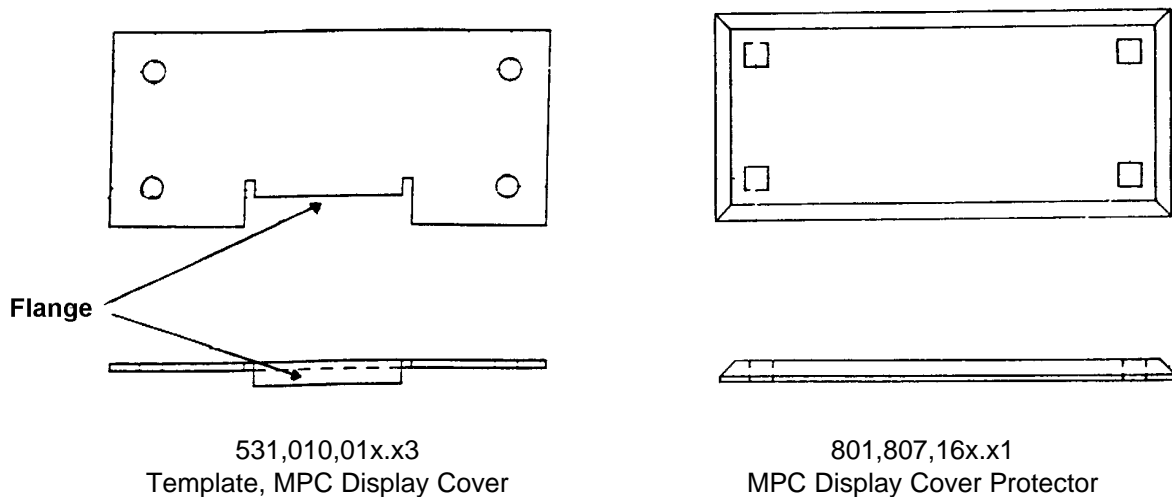

INSTALLATION INSTRUCTIONS:

1. **Unplug the vender.**
2. Remove the MPC display board assembly and window.
3. Straighten any damaged metal in the area around the display window mounting hole.
4. Place the MPC Display Cover Template so the flange is in the display window cut out. **IMPORTANT: The template flange should rest against the bottom edge of the display window cut out. See figure 1 below.**
5. While holding the template in position, mark the four (4) securing holes.
6. Remove template.
7. Drill a 9/32" hole at each of the four (4) positions marked in step 5. Ensure you do not drill in any wiring or parts. Also, ensure that metal filings, from drilling, do not get on the switches, coin mechanism or electrical connections.
8. Place the MPC Display Cover Protector in position. See figure 2 on page 3.
9. Secure the MPC Display Cover Protector with four (4) carriage bolts and four (4) keps nuts provided in the kit.
10. Place the display window in position. See figure 3 on page 3.
11. Secure the display window with the metal display window standoffs provided in the kit. See figure 3 on page 3.
12. Place one nylon washer (provided in kit) on each metal standoff. See figure 3 on page 3.
13. Place MPC Display Board in position and secure with nylon hex nuts. See figure 3 on page 3.
14. Plug in and test for proper operation.

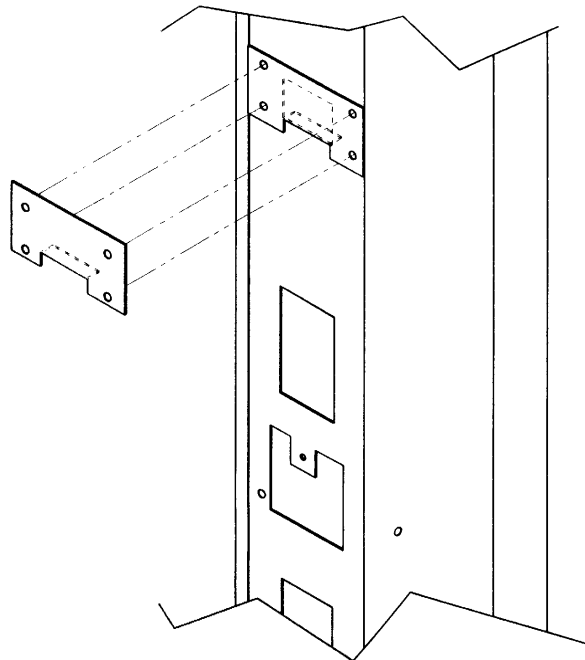

Figure 1

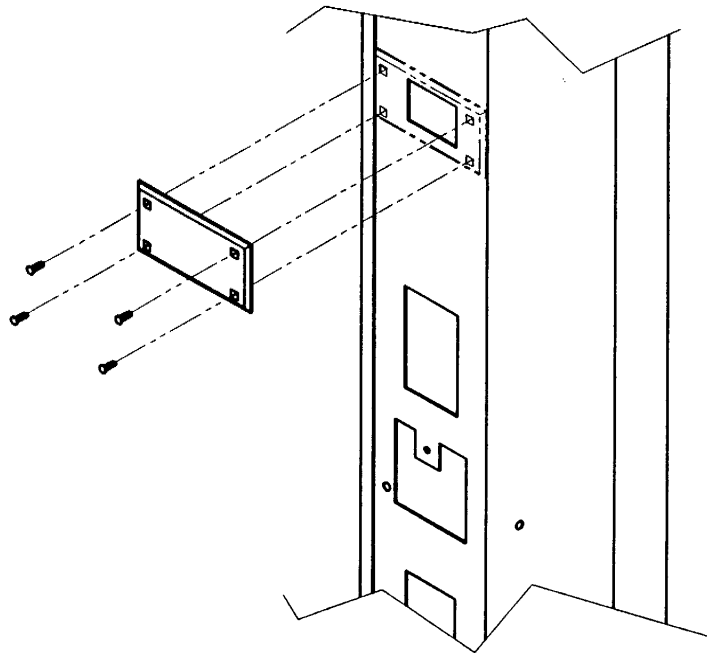

Figure 2

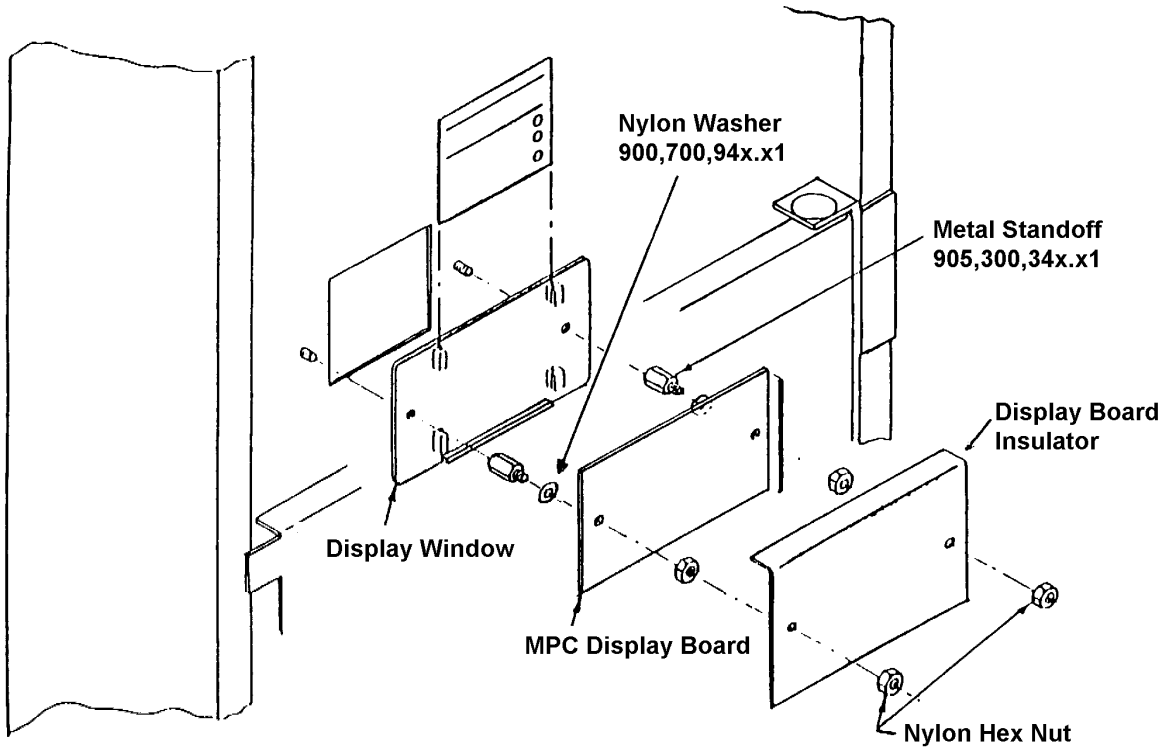

Figure 3